



CYKLOP
INTERNATIONAL

THE
STRAPPING
COMPANY

100 YEARS
1912/2012



ART. NAAM : ACRO-FQC2
ART. NR : 871017**
871018**

SPECIFICATION:

- PSE: OPTIONS 1,2,3.
- T: OPTION 4.
- CBL: OPTION 5.
- F1: OPTION 7.
- F2: OPTION 7.
- SK: OPTION 6 + SK CONNECTOR
- TS: TOPSWITSCH
- ATT: TOPSWITSCH + PLC CONNECTOR
- PLC: PLC CONNECTOR
- FS: FOOT SWITCH CONNECTOR
- TS-PLC: PLC-TOPSWITSCH CONNECTOR
- TOS: TOS CONNECTOR

Highest Page No. : 5
No.of pages : 4

	Date	5-12-2013
	Eng.	w.vegt
Tek. nr	Chkd	17-3-2015
Chg	Date	Name

ACRO-FQC2

CYKLOP THE
STRAPPING
COMPANY
INTERNATIONAL

100 YEARS
1912/2012

Benjamin Franklinstraat 5
8013 NC ZWOLLE
Tel. 038 - 4675800
Fax. 038 - 4675839

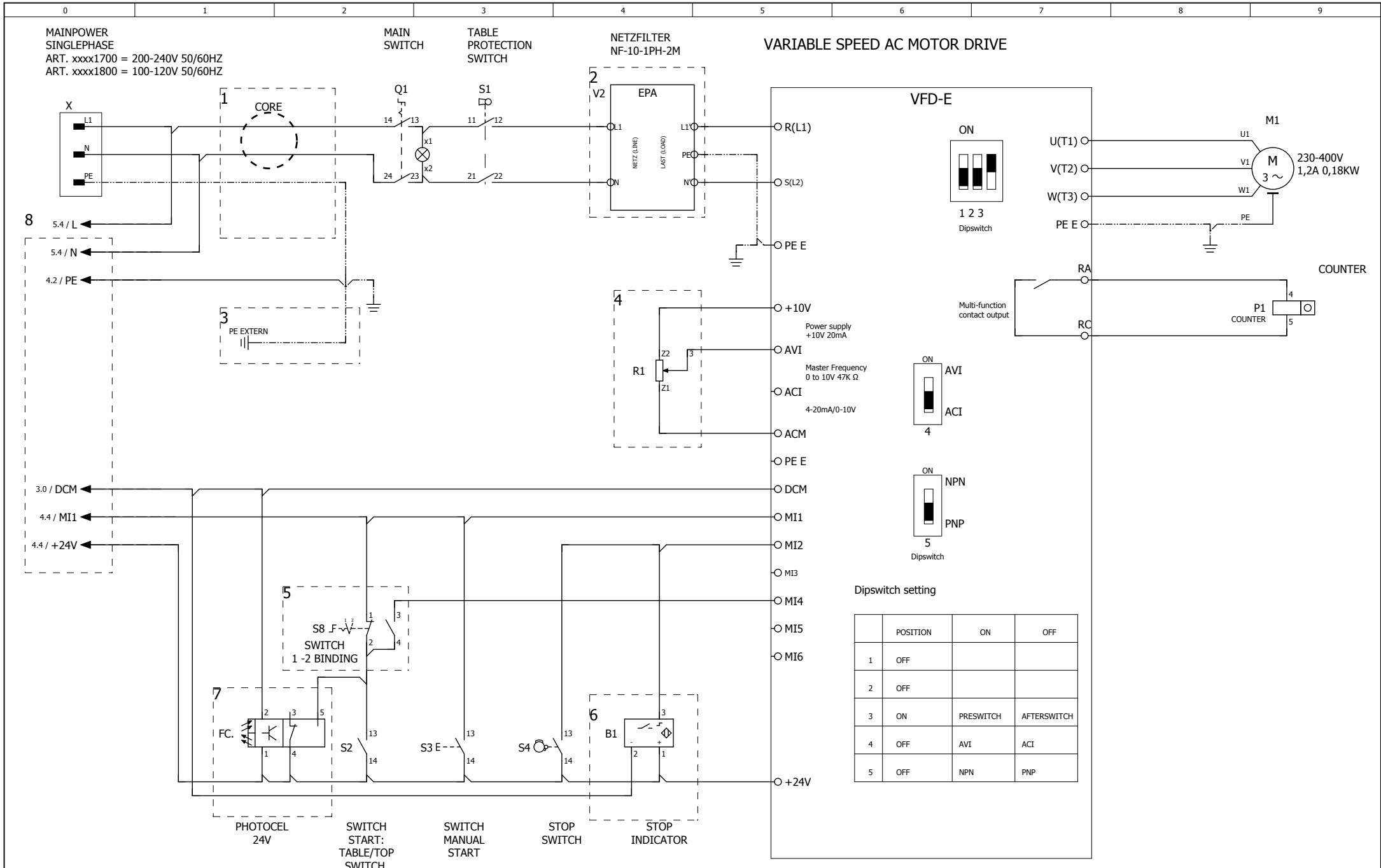

1			Date	5-12-2013
			Eng.	w.vegt
Tek. nr			Chkd	17-3-2015
Chg	Date	Name	Norm	

ACRO-FQC2
 CONTROL DIAGRAM



Benjamin Franklinstraat 5
 8013 NC ZWOLLE
 Tel. 038 - 4675800
 Fax. 038 - 4675839

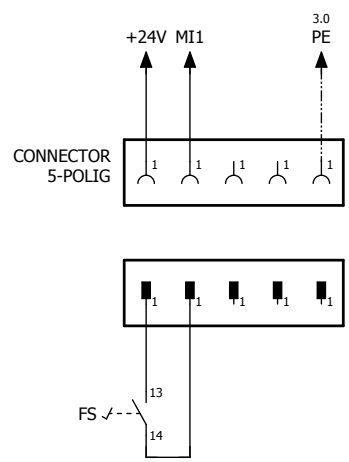

FOOT SWITCH

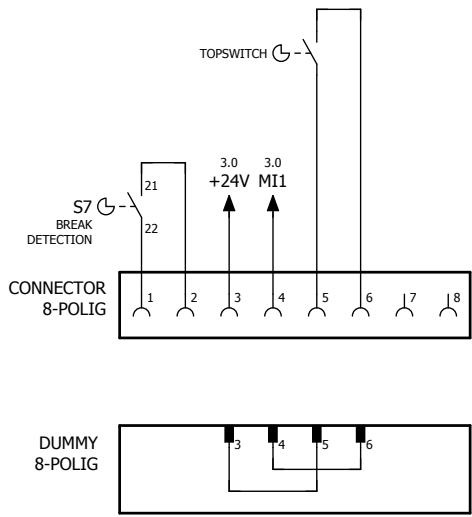

PLC - TOPSWITCH

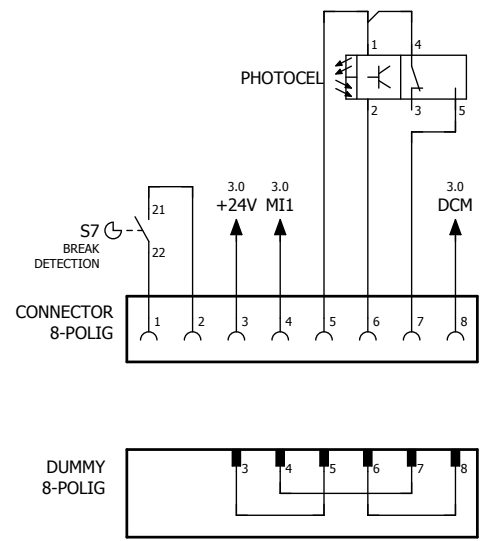

PLC - PHOTOCEL
PLC - CBT42

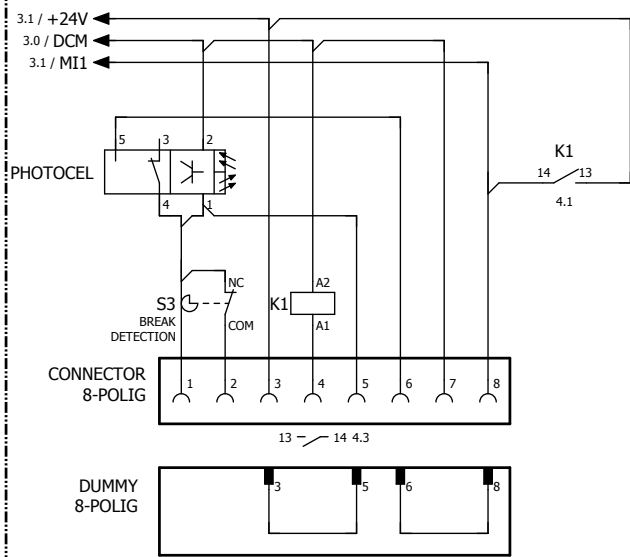

BTM

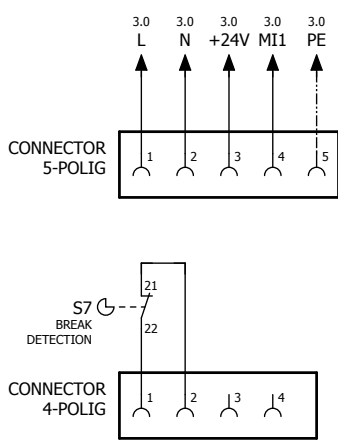

TOS

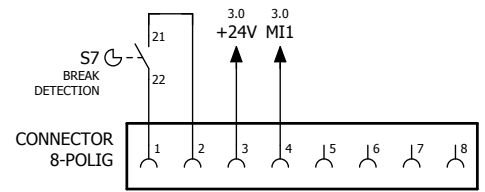

PLC

Date	5-12-2013		
Eng.	w.vegt		
Chkd	17-3-2015		
Chg	Date	Name	Norm

ACRO-FQC2
CONNECTORS



Benjamin Franklinstraat 5
8013 NC ZWOLLE
Tel. 038 - 4675800
Fax. 038 - 4675839

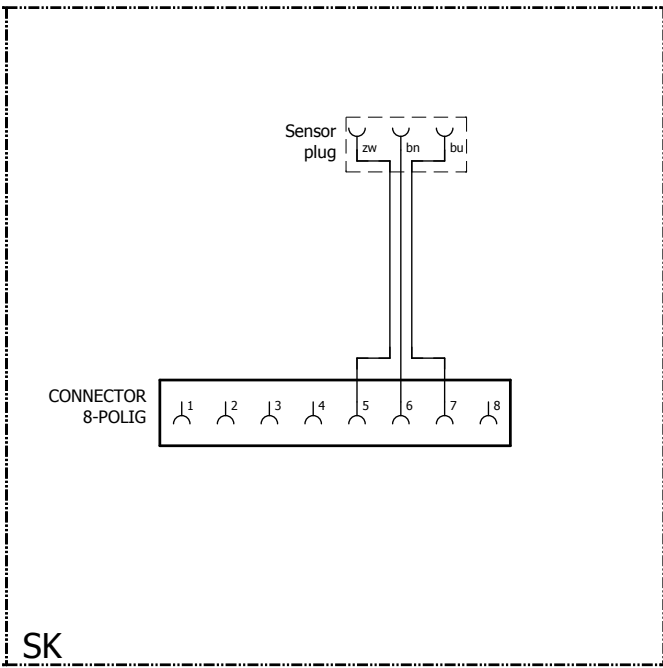
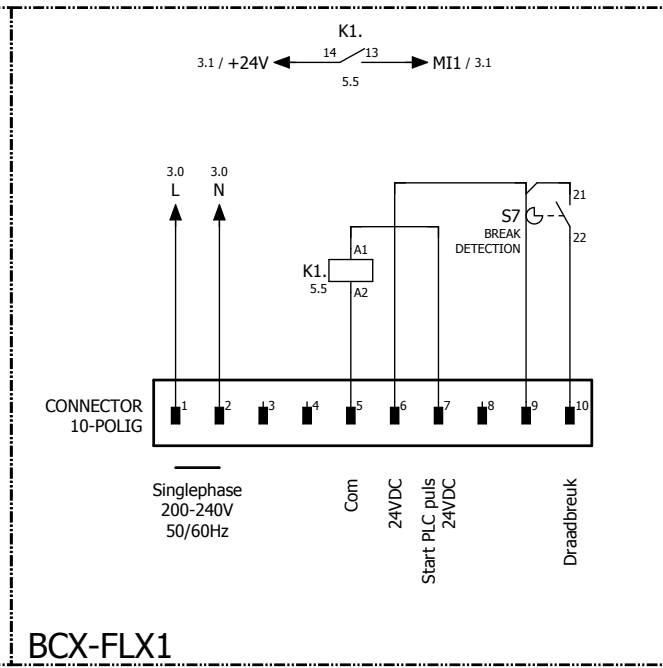
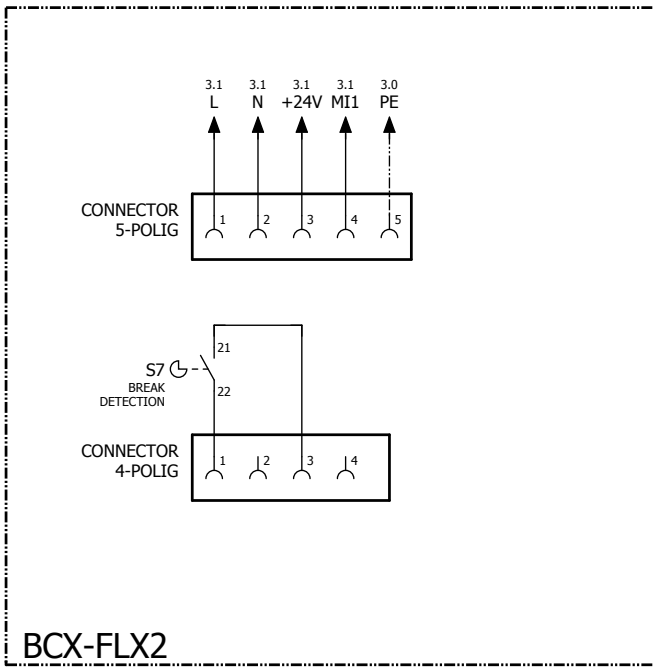

		Date	5-12-2013
		Eng.	w.vegt
Tek. nr		Chkd	17-3-2015
Chg	Date	Name	Norm

ACRO-FQC2
CONNECTORS



Benjamin Franklinstraat 5
8013 NC ZWOLLE
Tel. 038 - 4675800
Fax. 038 - 4675839